

# SAPO

25/2700.xx

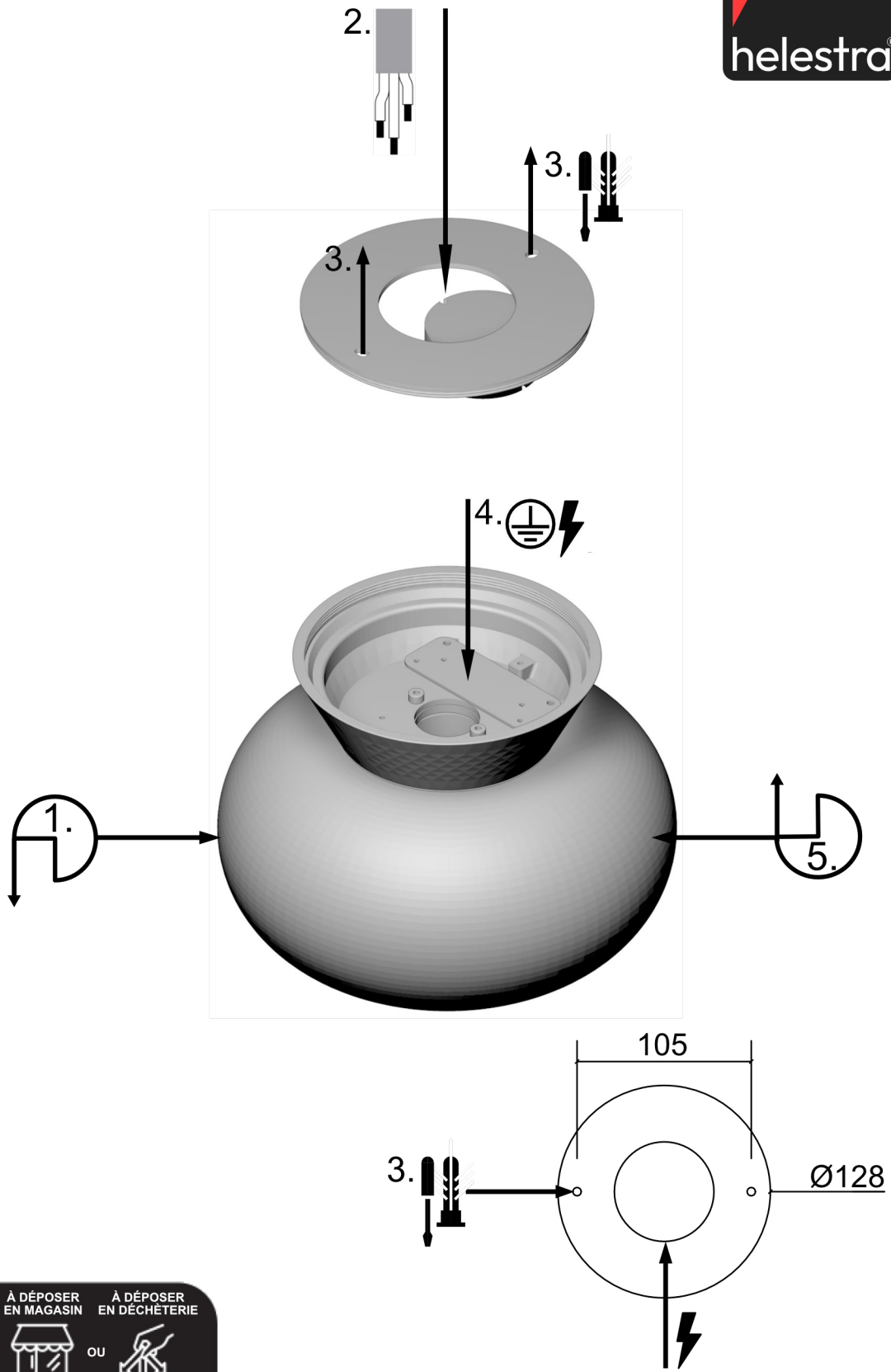

**FR**  
**Cet appareil se recycle**  
 À DÉPOSER EN MAGASIN ou À DÉPOSER EN DÉCHÈTERIE

Points de collecte sur [www.quefairedemesdechets.fr](http://www.quefairedemesdechets.fr)

Bitte beachten Sie unsere allgemeinen Hinweise !  
 Please observe our general information !  
 Nous vous prions d'observer nos instructions générales !  
 Observe por favor nuestra información general !

F

Dieses Produkt enthält eine Lichtquelle der Energieeffizienzklasse

This product contains a light source of energy efficiency class

Ce produit contient une source lumineuse de classe d'efficacité

[www.helestra.de/installation](http://www.helestra.de/installation)

**SAPO**   
25/2700.xx

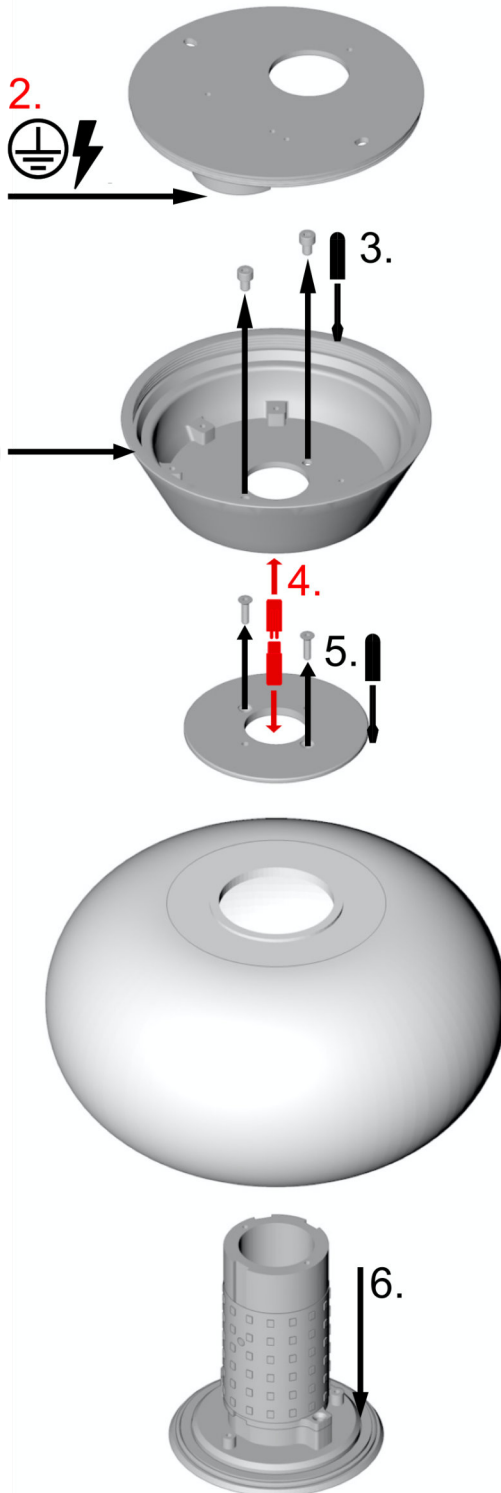
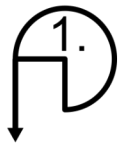
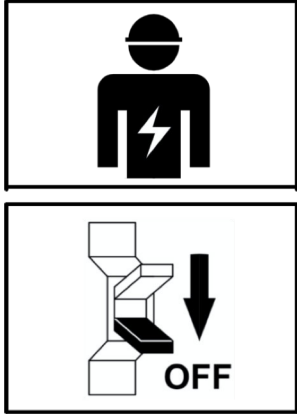

Glas austauschen  
Replace glass



2.  
Strom abklemmen  
Disconnect the power supply

3. & 5.  
Schrauben lösen  
Loosen screws

 4.  
Stecker lösen  
Disconnect the plug



**FR**  
Cet appareil  
se recycle



Points de collecte sur [www.quefairedemesdechets.fr](http://www.quefairedemesdechets.fr)

Bitte beachten Sie unsere allgemeinen Hinweise !  
Please observe our general information !  
Nous vous prions d'observer nos instructions générales !  
Observe por favor nuestra información general !

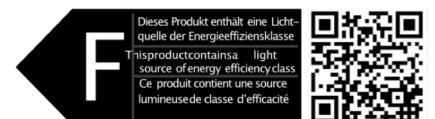

[www.helestra.de/installation](http://www.helestra.de/installation)

**Helestra Leuchten GmbH**  
An den Breiten 7, 01454 Leppersdorf, Deutschland/Germany

[www.helestra.de](http://www.helestra.de)